

1 ATTACHMENT TYPE 1
 SD-1 SCALE: 1-1/2" = 1'-0"

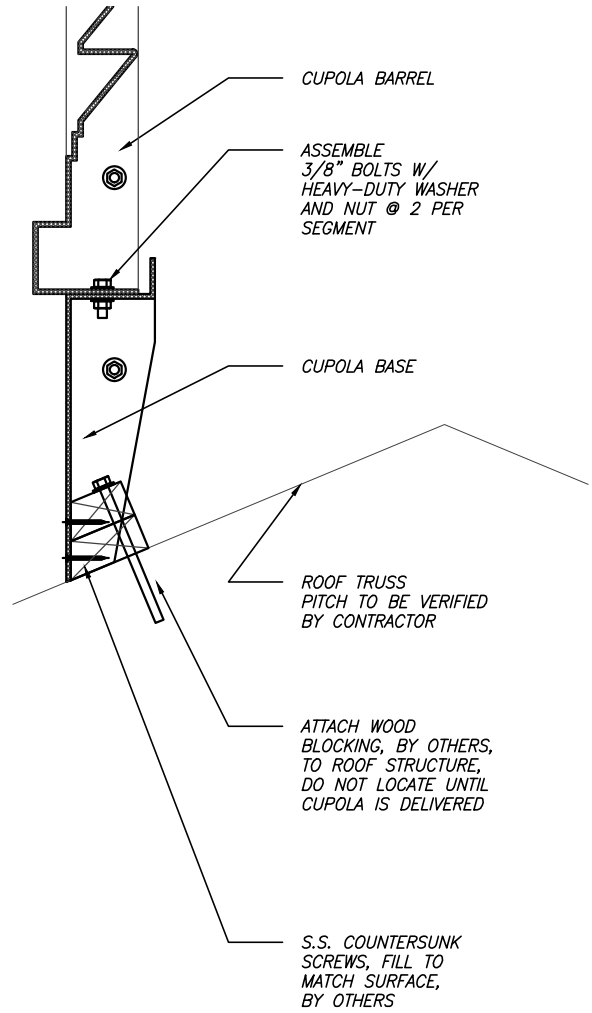

2 ATTACHMENT TYPE 2
 SD-1 SCALE: 1-1/2" = 1'-0"

CUPOLAS
 SHEET NO.
SD-01
 UPDATED: JAN 2010

ATTACHMENT
 DETAILS



ARCHITECTURAL FIBERGLASS, INC.

8300 BESSEMER AVE., CLEVELAND, OHIO 44127-1839
 (216) 641-8300 - FAX:(216) 641-8150
 www.fiberglass-afi.com